

Also available (additional fees apply)

1-**ACCESSORIES:** Wheel bearings, wheel cylinders, disc brake calipers, pistons, u-joints, alternator, starter, air conditioning compressor, powertrain electronic sensors;

2-**TURBO OR SUPERCHARGER ENGINE:** Oil pan, internal parts, turbocompressor valves, turbocompressor, sensors and electronic control;

3-**FOUR-WHEEL DRIVE OR ALL-WHEEL DRIVE:** Housing and all internally lubricated parts: main shaft, gear group, sprocket and chain, bearings, shims. Gaskets and oil seals are covered only when covered parts are repaired.



www.garantievc.ca
1 (800) 268-3284

REVTHE2014020NAN



*Plan 1: Less than 12 years and less than 220,000 km



*Plan 2: Less than 10 years and less than 200,000 km



*Plan 3: Less or equal to 8 years and less than 160,000 km
option accessories



*Plan 4: Less or equal to 6 years and less than 160,000 km
with accessories

*Coverage ranging from 6 to 36 months. Check with your dealer for more information about the coverage you need.

*Protection ranging from \$2,000 to \$9,000

*The present leaflet has been created for information only and on no account should it serve to modify the terms and conditions of the **The Essential** warranty. The customer must refer to the contract.*

Check with your dealer to learn more about the benefits offered by **The Essential warranty and drive with confidence!**



GUARANTEE V.C.

division of
THE VCG GROUP

**Drive with
confidence!**

With our new warranty : **The Essential**



The Essential...

1-ENGINE (FUEL OR DIESEL): All internally lubricated parts (when damage is caused by mechanical failure or breakdown of an internal engine part covered by the Warranty, except if breakdown is caused by overheating) including : The head gasket, engine block, cylinder heads, crankshaft and main bearings, crankshaft gears, connecting rods and bearings, camshaft and bearings, camshaft gears, push rods, pistons, rings and pins, intake and exhaust valves, valve springs and retainers, guides, hydraulic lifters, rocker arm, shafts and pivots, harmonic balancer and pulleys, timing chain, flywheel, oil pump and shafts, ring gear, and oil if necessary after agreement with the repair shop. The following items are covered only if damage is due to a breakdown of a lubricated internal part: oil pan, engine torque struts, valve covers, timing belt and gears, timing belt tensioners and guides. Gaskets and oil seals are covered only when covered parts are repaired;

2-AUTOMATIC TRANSMISSION: All internally lubricated parts when the damage is internal including: Torque converter, valve body, gear sets, main and intermediate shafts, clutches and bands, vacuum modulator, oil pump, oil pan, governor and oil if necessary after agreement with the repair shop. Gaskets and oil seals are covered only when covered parts are repaired;

3-MANUAL TRANSMISSION: All internally lubricated parts when the damage is internal including: Housing, main and intermediate shafts, gear sets, synchronizer rings, shifter fork and bearings and oil if necessary after agreement with the repair shop. Gaskets and oil seals are covered only when covered parts are repaired;

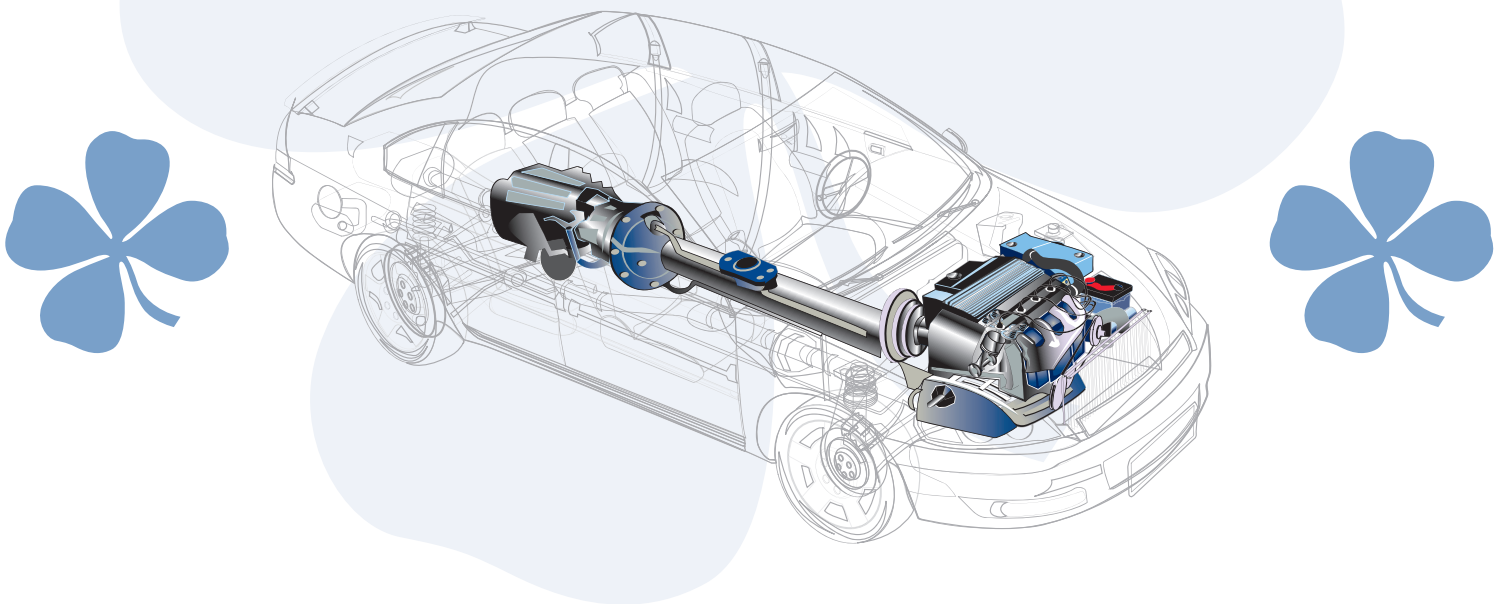

4-DIFFERENTIAL

4.1 Rear Wheel Drive: All internally lubricated parts when damage is internal including: Carrier gear and case drive pinion and pinion gear, differential cover, bearings and oil if necessary after agreement with the repair shop. Gaskets and oil seals are covered only when covered parts are repaired;

4.2 Front Wheel Drive: Transaxle: All internally lubricated parts when damage is internal including: Housing, main shafts, crown and pinion, pinion gears and bearings. Gaskets and oil seals are covered only when covered parts are repaired;

5-TRANSFER CASE: 4 wheel drive or all wheel drive (AWD) vehicles: Housing and all internally lubricated parts: main shaft, gear group, sprocket and chain, bearings, shim. Gaskets and oil seals are covered only when covered parts are repaired;

6-STEERING: Housing, valve assembly, rack in pinion, power steering pump;

7-TOWING: A towing allowance of **\$75.00** (plus taxes) per occurrence applies to any breakdown or mechanical failure covered by the Contract, unless the total amount of the Additional Warranty payable by **Guarantee V.C.** has been exceeded.